

**QUALITY :** METAL USED IN THE MANUFACTURE OF CASTINGS CONFORM TO ASTM 126 CLASS B  
 : THREADS COMPLY WITH THE REQUIREMENTS OF TIS. 281-2532  
 : HOT DIP-GALVANIZED COMPLY WITH THE REQUIREMENTS OF ASTM A153  
 THICKNESS 86 MICRONS

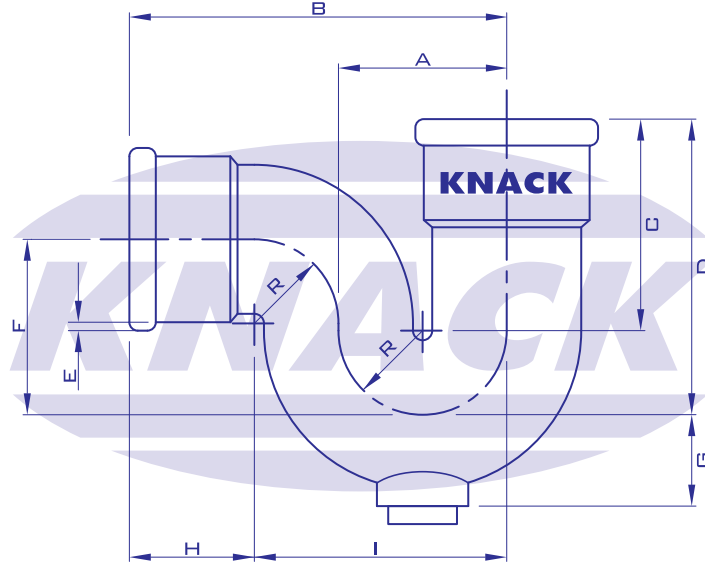

**MODEL**

**P-TRAP**

Pipe Size Inch	A	B	C	D	E	F	G	H	I	R
1 1/2	62	136.5	106.5	137.5	3	99.5	30.5	43.5	93	31
2	70	157	88	123	4	73	41	52	105	35
2 1/2	75	158	86.5	124	4	75	47	45.5	112.5	37.5
3	90	191.5	93.5	138.5	5	77	51.5	57.5	134	45
4	127	239	119.5	183	7	99	94	51.5	124	63.5

**MODEL**

**MALE THREAD ADAPTOR**

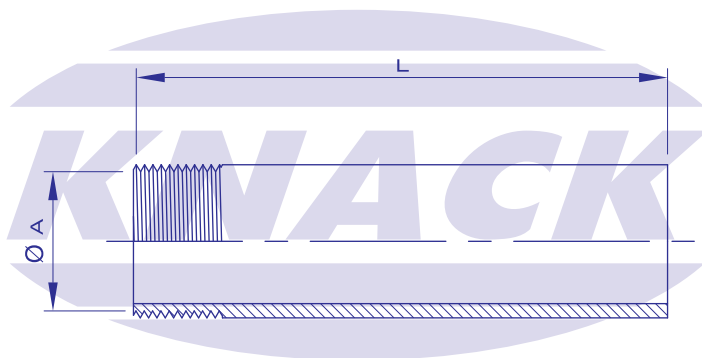

Pipe Size Inch	A	L
2	PT 2"	300
3	PT 3"	300
4	PT 4"	300
6	PT 6"	300
8	PT 8"	300