

****THREADED ROD NOT INCLUDED****

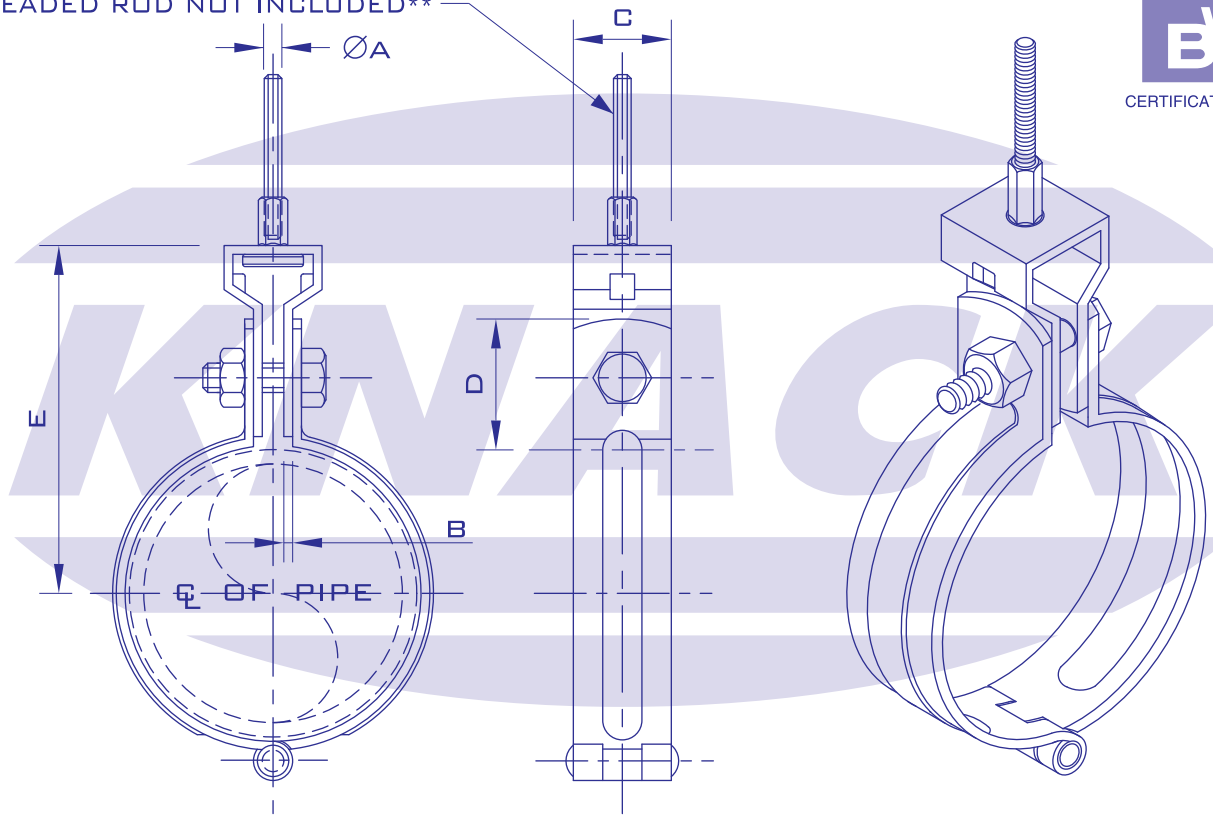

FIGURE H 523 SPLIT RING HANGER WITH SWIVEL ADJUSTABLE

MATERIAL : CARBON STEEL

FINISH : PLAIN, PAINT, ELECTRO - GAVANIZED

NOMINAL PIPE SIZE		ROD SIZE A		BOLT SIZE	B	C	D	E
INCH	MM.	INCH	MM.					
1/2	15	3/8	9.5	1/4 x 25	1.8	25	28	68
3/4	20	3/8	9.5	1/4 x 25	1.8	25	28	71
1	25	3/8	9.5	1/4 x 25	1.8	25	28	74
1 1/4	32	3/8	9.5	1/4 x 25	1.8	25	28	78
1 1/2	40	3/8	9.5	1/4 x 25	1.8	25	28	81
2	50	3/8	9.5	5/16 x 25	2.3	25	28	87
2 1/2	65	3/8	9.5	5/16 x 25	2.3	25	28	95
3	80	3/8	9.5	5/16 x 25	2.3	25	28	102
4	100	3/8	9.5	5/16 x 25	2.3	25	28	114
6	150	1/2	12.7	1/2 x 45	3.2	32	36	153
8	200	5/8	15.9	1/2 x 45	4.5	38	36	180