



บริษัท แหน็ค ส. เจริญกิจ จำกัด  
KNACK S. CHAREONKIJ CO.,LTD.

# FLOOR DRAIN (ไม่มีถ้วยดักกลิ้น)

MODEL : 100 SC (สำหรับท่อ PVC ขนาด 2"-2 1/2")

ISO 9001

BUREAU VERITAS  
Certification

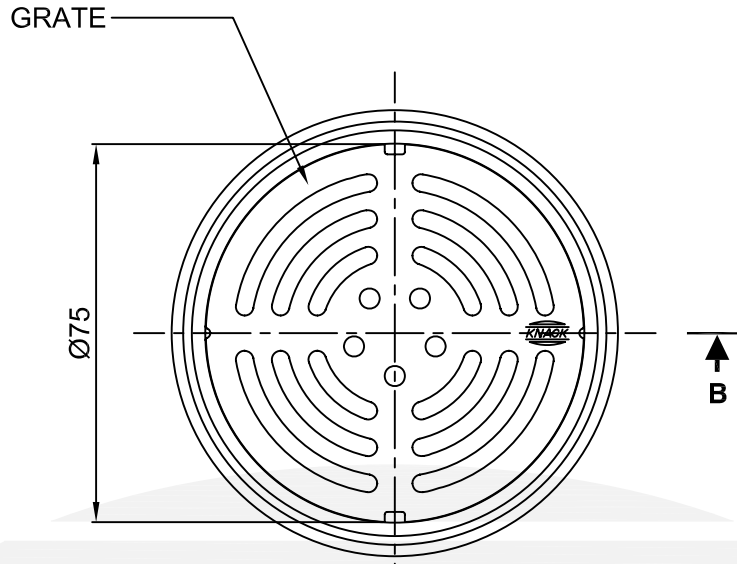

TOP VIEW

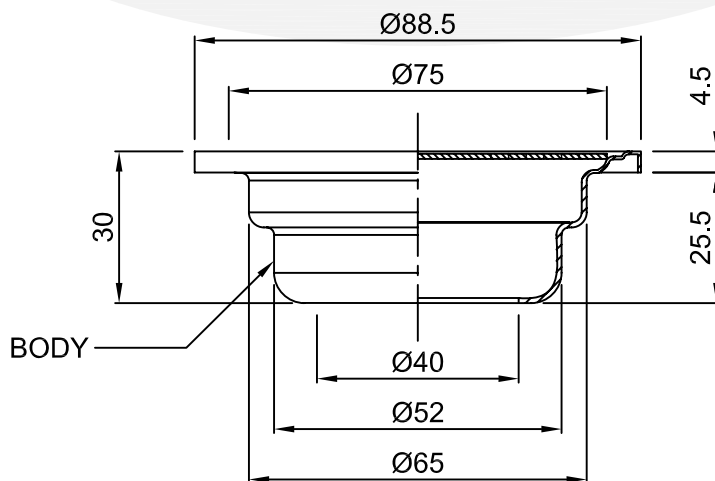

SECTION A - B

| CUSTOMER                   |            | N/A      |             |       |         | PROJECT      |     | N/A               |               |
|----------------------------|------------|----------|-------------|-------|---------|--------------|-----|-------------------|---------------|
| DRAWN                      | CH.WORAWIT | DATE     | 9 / 03 / 56 | REV.  | 00      | RANGE (MM.)  |     | TOLERRANCES CHECK |               |
| DWG.No.                    | 0903566-D1 | WORKTYPE | MTO         | SCALE | 1 : 1.5 |              |     | CASTING (MM.)     | MACHING (MM.) |
| DIMENSION IN MM.           |            |          |             |       |         | 0 - 99       | ± 1 | ± 0.5             |               |
| MATERIAL                   |            |          |             |       |         | 100 - 149    | ± 2 | ± 0.8             |               |
| STAINLESS STEEL GRADE 18-8 |            |          |             |       |         | 150 - 499    | ± 3 | ± 1               |               |
| FINISHING                  |            |          |             |       |         | 500 - 999    | ± 6 | ± 2               |               |
| -                          |            |          |             |       |         | 1000 - UPPER | ± 8 | ± 3               |               |