



บริษัท แหน็ค ส. เจริญกิจ จำกัด  
KNACK S. CHAREONKIJ CO.,LTD.

# MANHOLE GRATE (มี BOLT ล็อค)

MODEL : ฝาบอทุกเหล็กหล่อเหนียว (ในผิวจราจร)  
ตะแกรงชนิดเหลี่ยม-แบบรางวี 390x390x75 MM.

ISO 9001

BUREAU VERITAS  
Certification

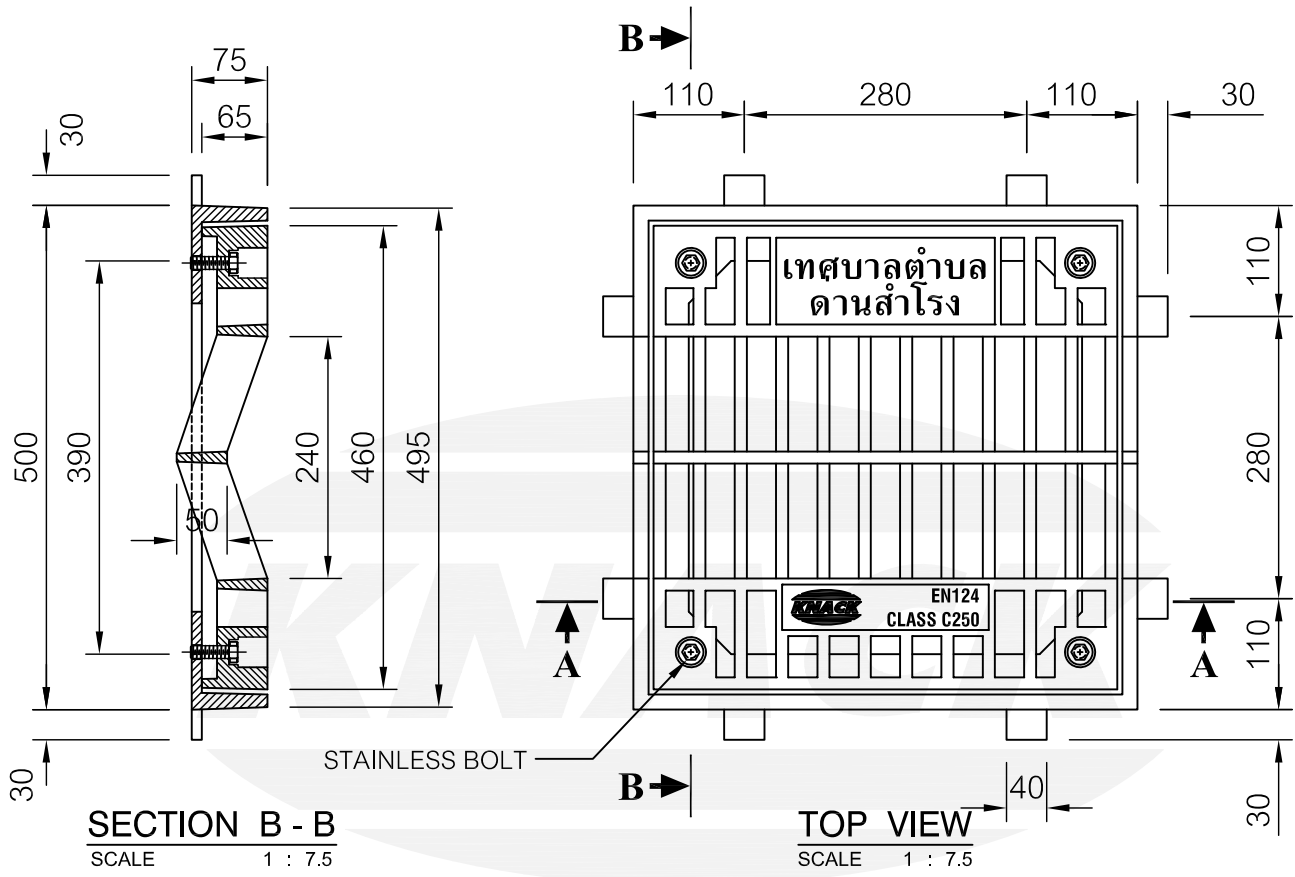

**SECTION B - B**  
SCALE 1 : 7.5

**TOP VIEW**  
SCALE 1 : 7.5

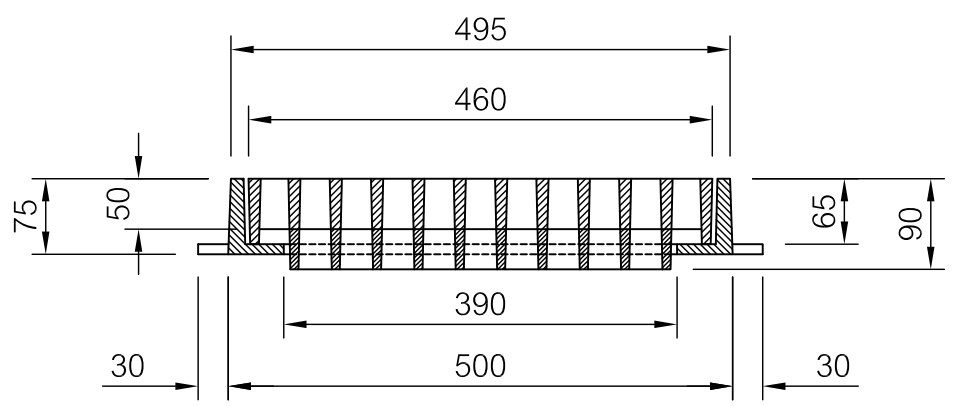

**SECTION A - A**  
SCALE 1 : 7.5

\*Capacity Load = 25 Ton

MATERIAL	CONFORMS WITH BS EN124
DUCTILE CAST IRON COMPLY WITH ISO 1083 GRADE 500-7	
FINISHING	
COATING WITH ACRYLIC MATT # BLACK COLOR	III DIMENSION IN MM. III



บริษัท แหนค ส. เจริญกิจ จำกัด  
KNACK S. CHAREONKIJ CO.,LTD.

# MANHOLE GRATE (มี BOLT ล็อค)

MODEL : ฝาบอทุกเหล็กหล่อเหนียว (ในผิวจราจร)  
ตะแกรงชนิดเหลี่ยม-แบบวางวิ 490x490x75 MM.

ISO 9001

BUREAU VERITAS  
Certification

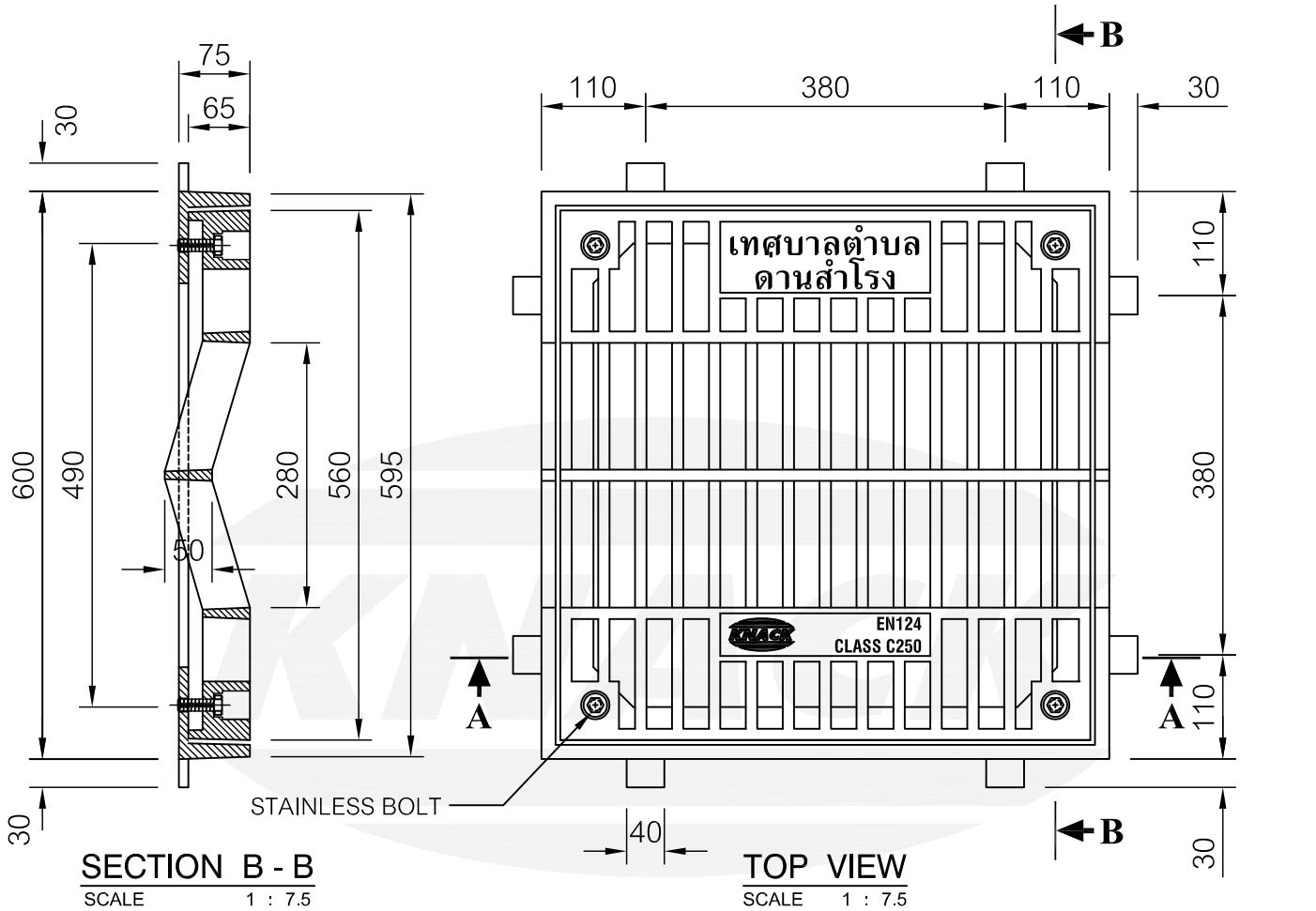

\*Capacity Load = 25 Ton

MATERIAL	CONFORMS WITH BS EN124
DUCTILE CAST IRON COMPLY WITH ISO 1083 GRADE 500-7	
FINISHING	
COATING WITH ACRYLIC MATT # BLACK COLOR	III DIMENSION IN MM. III



บริษัท แม็ค ส. เจริญกิจ จำกัด  
KNACK S. CHAREONKIJ CO., LTD.

**MANHOLE GRATE (มี BOLT ล็อค)**

MODEL : ฝาขอบปากเหล็กหล่อเหนียว (ในผิวจราจร)  
ตะแกรงชนิดเหล็กถลุง-แบบราง 540x940x75 MM.



**TOP VIEW**  
SCALE 1 : 10

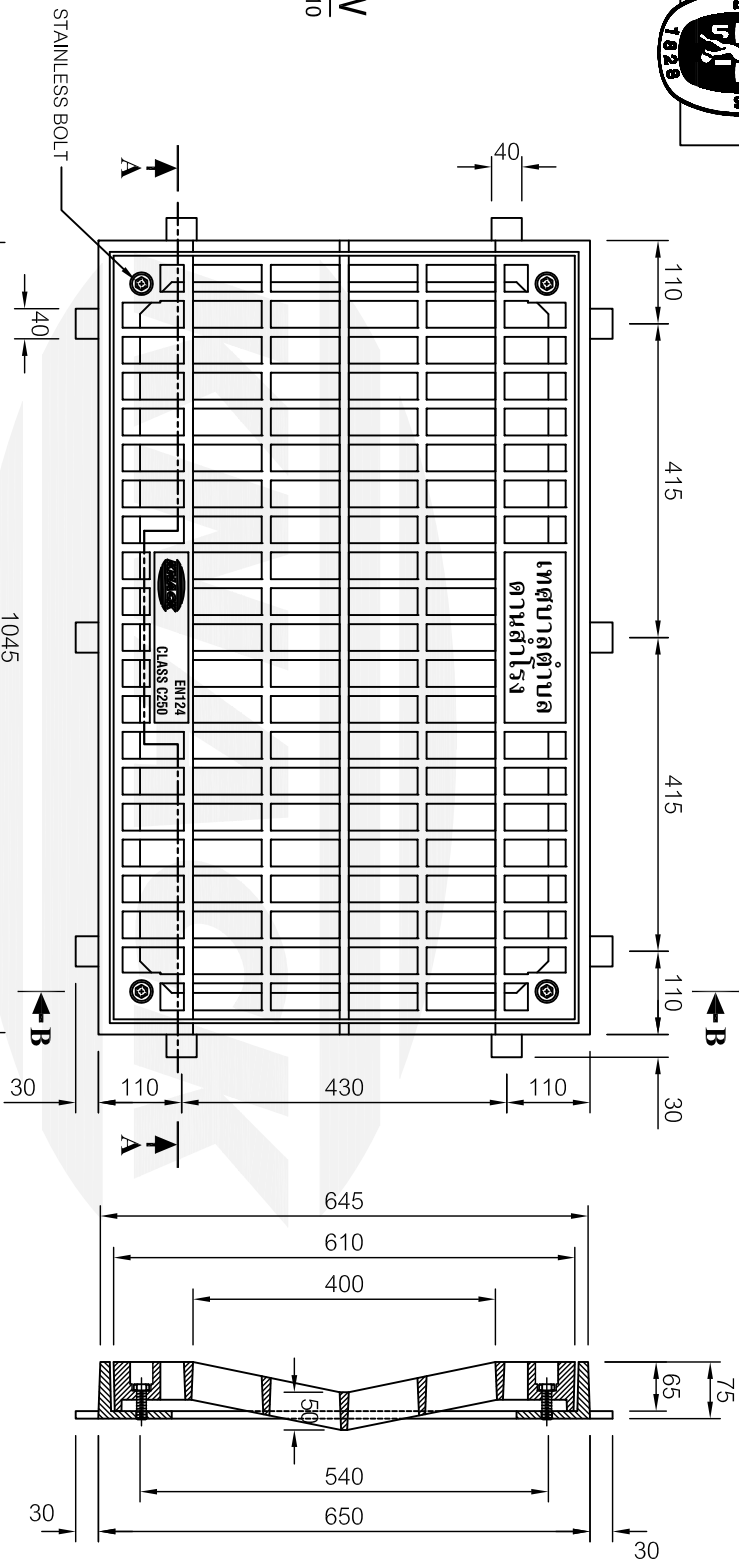

**SECTION A - A**  
SCALE 1 : 10

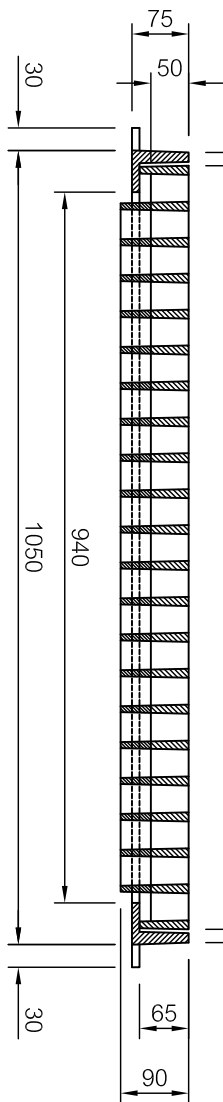

**SECTION B - B**  
SCALE 1 : 10

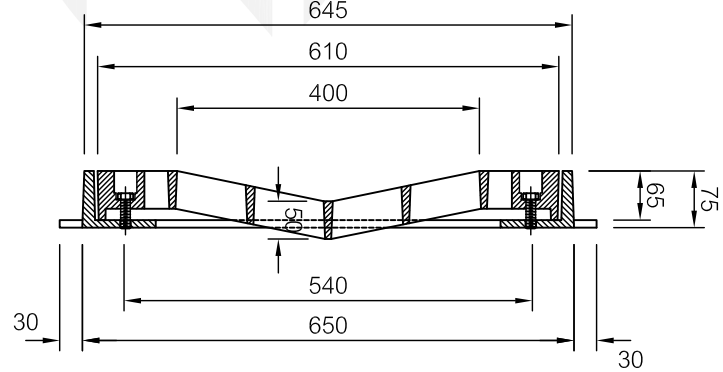

\*Capacity Load = 25 Ton

**MATERIAL**  
DUCTILE CAST IRON COMPL Y WITH ISO 1083 GRADE 500-7  
**FINISHING**  
COATING WITH ACRYLIC MATT # BLACK COLOR

**CONFORMS WITH BS EN124**  
**III DIMENSION IN MM. III**