

ISO 9001

BUREAU VERITAS
Certification

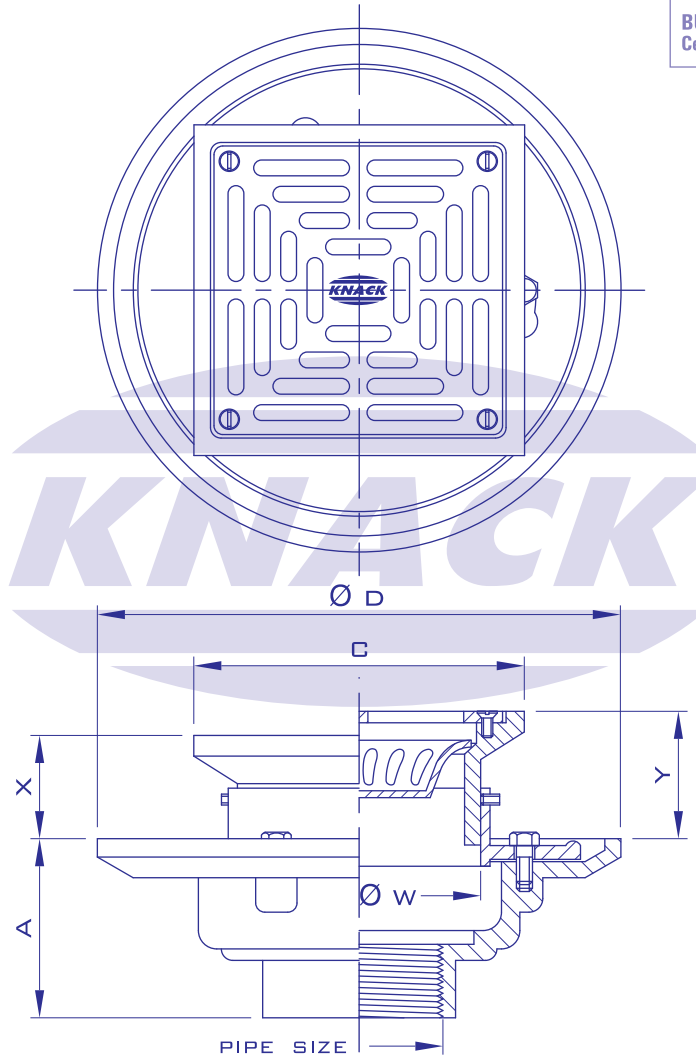

FLOOR DRAIN

MODEL 233 PS
(ตะแกรงสแตนเลส)

ADJUSTABLE STRAINER

Pipe Size Inch	A	C	D	W	Adjustment		Free Area (mm. ²)
					X	Y	
2	78	125	229	90	36	63	2890
2 1/2	78	125	229	90	36	63	2890
3	78	125	229	90	36	63	2890

