

ISO 9001

BUREAU VERITAS
Certification

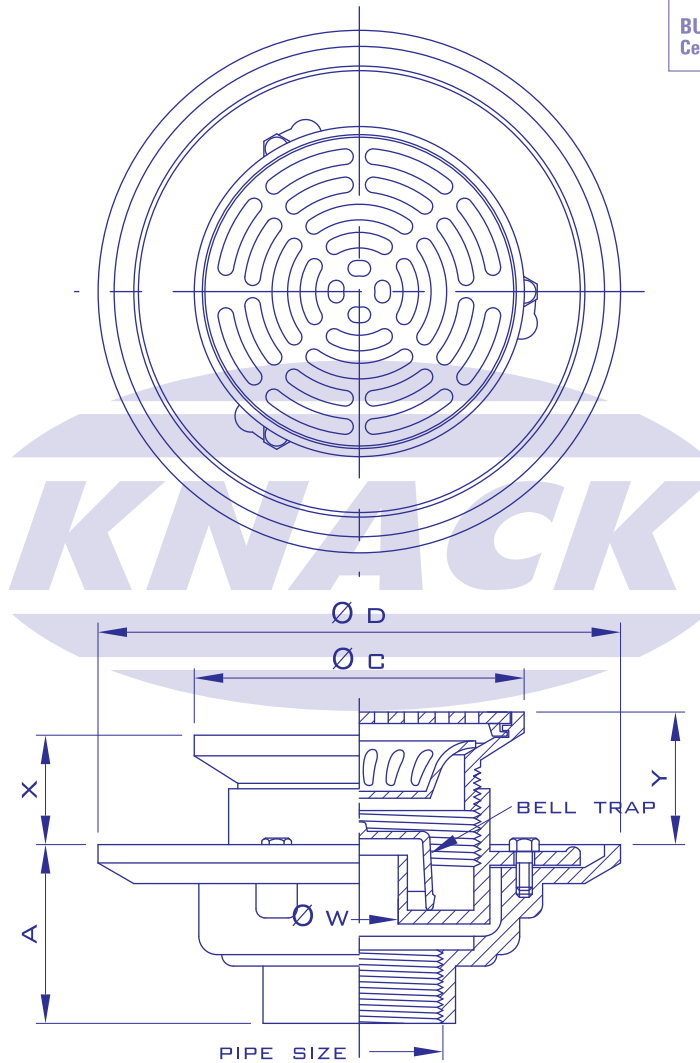

FLOOR DRAIN

MODEL 232 BM

ADJUSTABLE STRAINER

Pipe Size Inch	A	C	D	W	Adjustment		Free Area (mm. ²)
					X	Y	
1 1/2	78	120	229	37	55	70	2400
2	78	120	229	37	55	70	2400
2 1/2	78	120	229	37	55	70	2400
3	78	120	229	37	55	70	2400
4	78	197	268	96	62	80	6500
5	78	197	268	96	62	80	6500
6	78	197	268	96	62	80	6500
8	103	272	330	145	86	96	17200

