

ISO 9001

BUREAU VERITAS
Certification

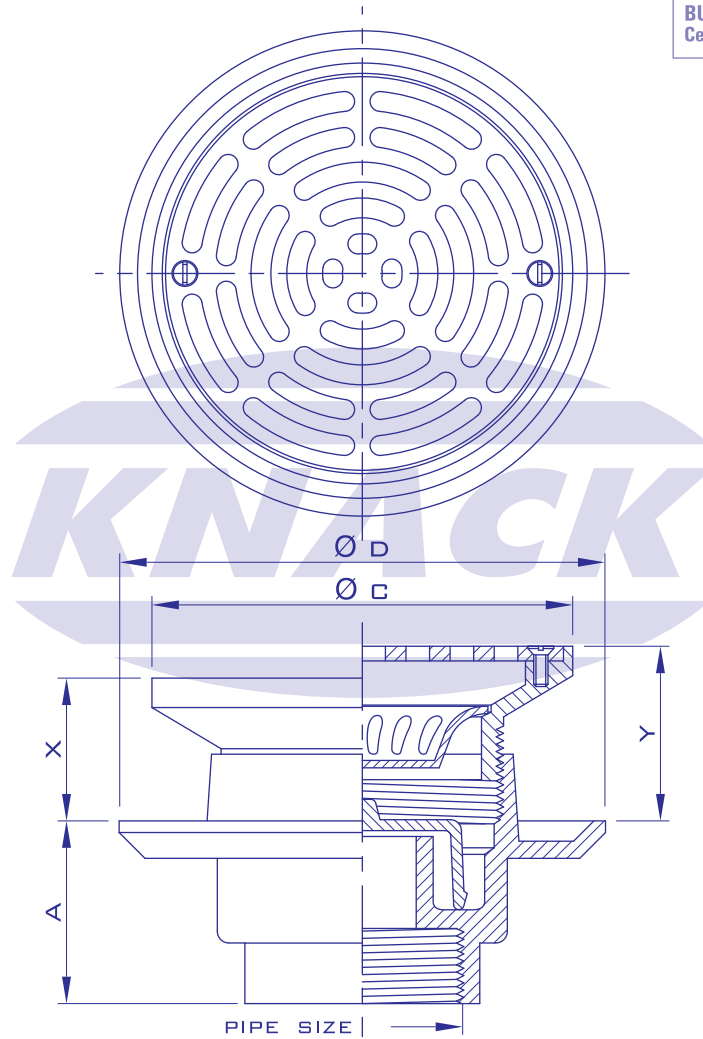

FLOOR DRAIN

MODEL 225

ADJUSTABLE STRAINER

Pipe Size Inch	A	C	D	Adjustment		Free Area (mm. ²)
				X	Y	
2	73	120	152	44	60	2400
2 1/2	73	120	152	44	60	2400
3	73	120	152	44	60	2400

