

ISO 9001

BUREAU VERITAS  
Certification

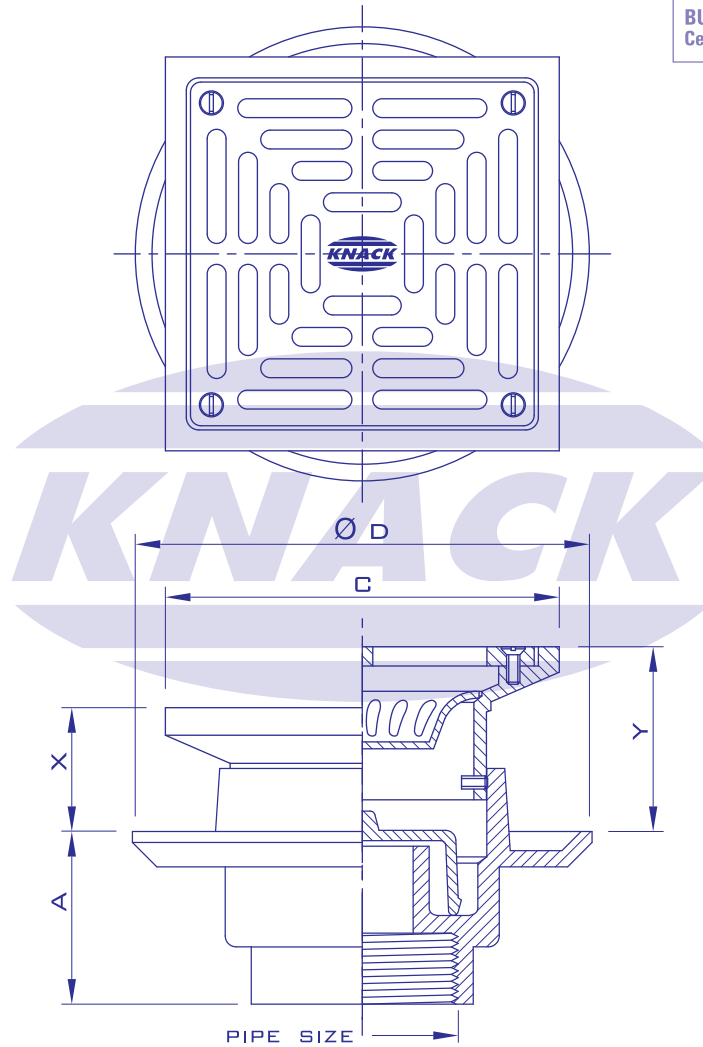

**FLOOR DRAIN**

**MODEL 225 G**

**ADJUSTABLE STRAINER**

Pipe Size Inch	A	C	D	Adjustment		Free Area (mm. <sup>2</sup> )
				X	Y	
2	73	125	152	28	56	2890
2 1/2	73	125	152	28	56	2890
3	73	125	152	28	56	2890
4	71	165	178	54	72	6900

