

ISO 9001

BUREAU VERITAS  
Certification

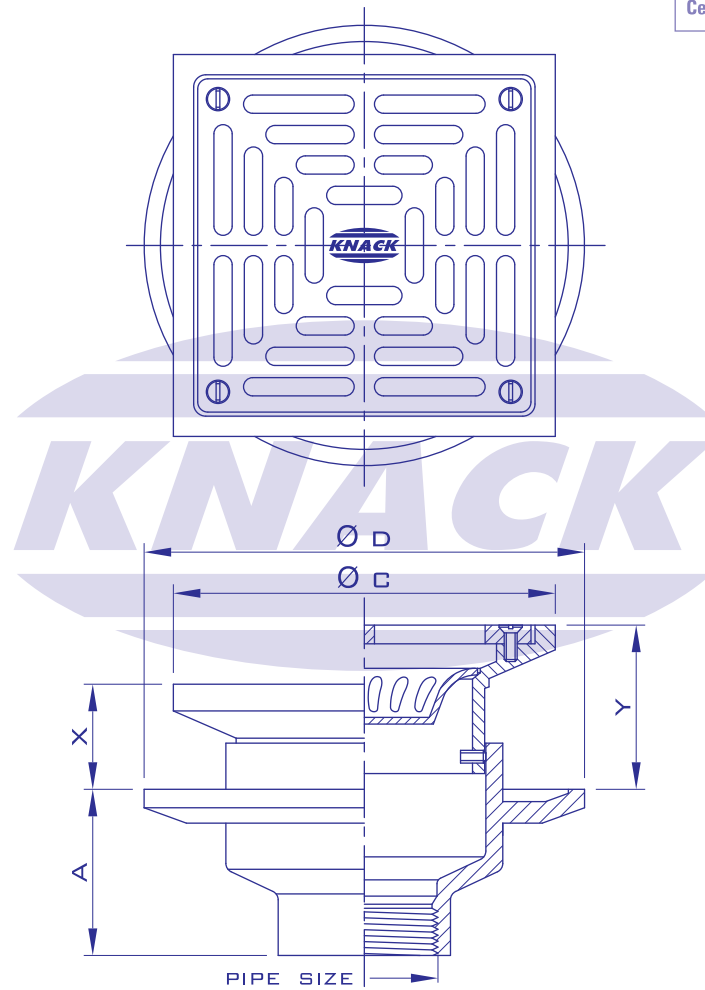

**FLOOR DRAIN**

**MODEL 224 PS**

**ADJUSTABLE STRAINER**

Pipe Size Inch	A	C	D	Adjustment		Free Area (mm. <sup>2</sup> )
				X	Y	
1 1/2	58	125	132	28	53	2890
2	58	125	132	28	53	2890
2 1/2	58	125	132	28	53	2890
3	58	125	132	28	53	2890
4	71	165	178	34	53	6900

