

ISO 9001

BUREAU VERITAS
Certification

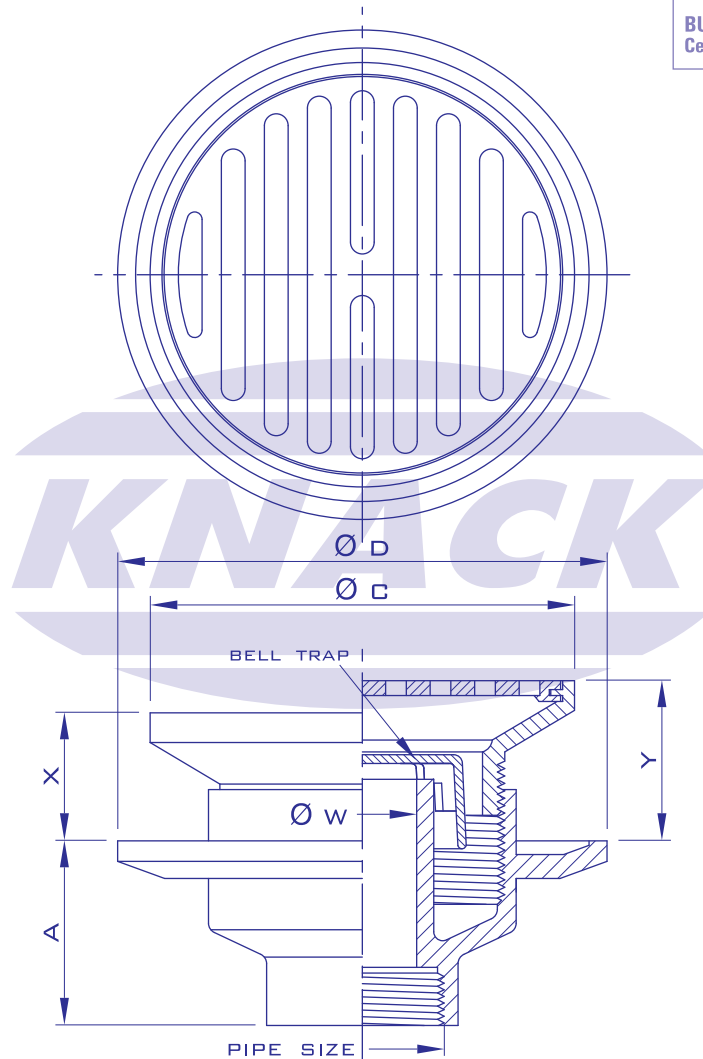

FLOOR DRAIN

MODEL 224 B

ADJUSTABLE STRAINER

Pipe Size Inch	A	C	D	W	Adjustment		Free Area (mm. ²)
					X	Y	
1 1/2	58	121	132	37	32	48	3500
2	58	121	132	37	32	48	3500
2 1/2	58	121	132	37	32	48	3500
3	58	121	132	37	32	48	3500
4	71	158	178	59	35	63	5000

