

ISO 9001

BUREAU VERITAS
Certification

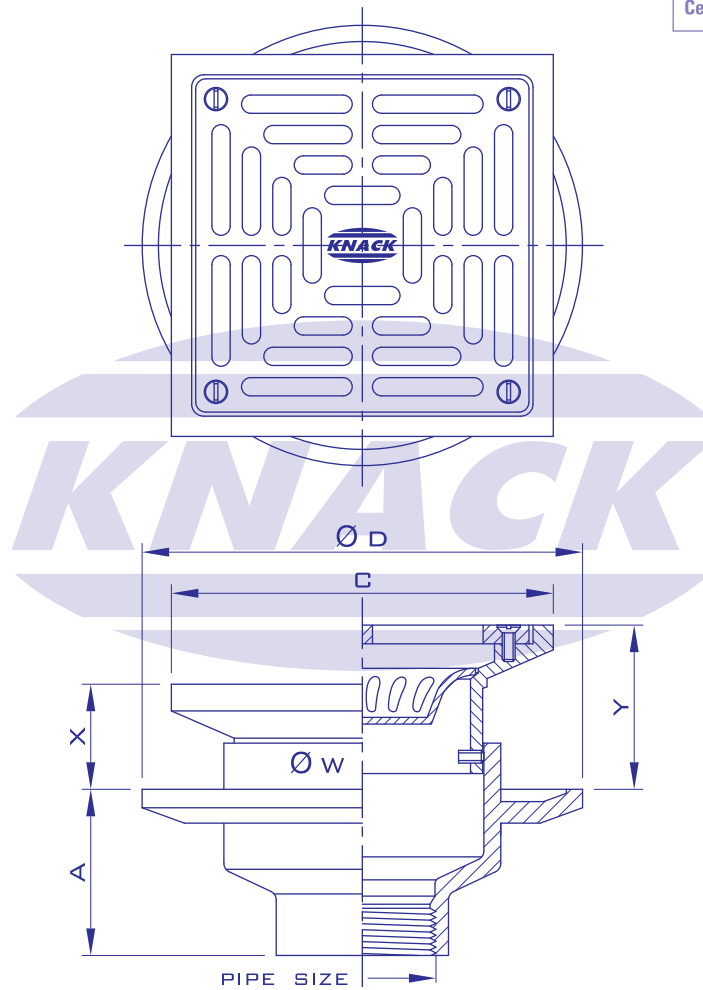

FLOOR DRAIN

MODEL 224 PG

ADJUSTABLE STRAINER

Pipe Size Inch	A	C	D	Adjustment		Free Area (mm. ²)
				X	Y	
2	58	125	132	28	53	2890
2 1/2	58	125	132	28	53	2890
3	58	125	132	28	53	2890
4	71	165	178	34	53	6900

